

Adding DRO Handwheels to Stepper Motors

Introduction

To install CNC stepper motor mounts on a Sherline machine, the handwheels must be removed. Sherline's digital readout system measures handwheel rotation and translates it electronically into table movement rather than measuring table movement directly; therefore removing the special DRO handwheels eliminates the DRO function. Some CNC users prefer to have a DRO reading the leadscrew movement to crosscheck the CNC input to insure that the axis has actually moved the amount of the stepper motor input. Though not part of the original design consideration for the DRO handwheels, there is a way they can be mounted to the back of a stepper motor so that they can be used in this application.

Parts Required

P/N 81300 is the DRO thrust collar that both centers the leadscrew and has a groove around its outer edge that locates the two halves of the encoder housing. These thrust collars can be ordered as replacement parts for \$4.00 each. You will need one for each stepper motor to which you wish to attach a DRO handwheel/encoder unit.

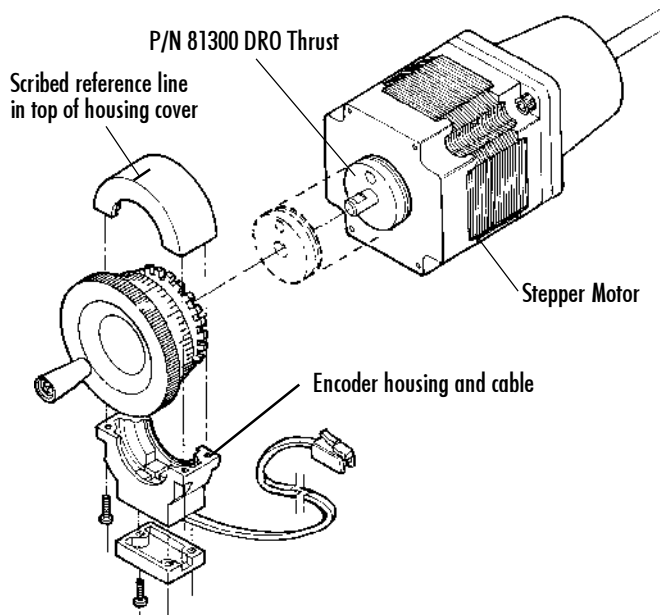

FIGURE 1—Grooved thrust collar from the DRO is shown glued to the back of the stepper motor. Note position of groove closest to stepper motor.

Installation of the thrust

Spread a thin layer of grease on the rear shaft of the stepper motor near the housing to keep any excess glue from sticking to the shaft. Make sure the back of the stepper motor housing around the shaft is flat and clean. Wipe the housing with rubbing alcohol to remove any excess grease or oil. Mix a small amount of 5-minute epoxy and spread it on the back of one of the thrust collars. (Note: the back side is the side closest to the groove in the outer periphery.) Keep glue away from the center hole. Slide

the thrust down the rear motor shaft and press it against the back of the stepper motor housing, making sure it seats squarely and that the shaft can turn freely. Repeat this for each stepper motor that will have a DRO handwheel mounted to it. Let the glue harden for several hours or overnight for maximum strength.

Redrilling the handwheel set screw hole if needed

Put the handwheel onto the motor shaft and see where the set screw hits the shaft. The additional thickness of the thrust collar means that the handwheel set screw may tighten too close to the end of the motor shaft. It might be necessary to drill and tap a new 10-32 hole in the handwheel as close to the plastic encoder gear as possible so that the set screw will fully engage the shaft. If the set screw does tighten on the shaft, this step will not be necessary. If a new hole is needed, the handwheel can be slipped over a 1/4" diameter wooden dowel or other 1/4" rod which is held in the grooved jaw of the mill vise. Secure the handwheel to the shaft with the existing set screw. Drill the new #21 (0.1590") hole. Remove the handwheel from the shaft and tap the hole 10-32. Reuse the existing set screw in the new hole.

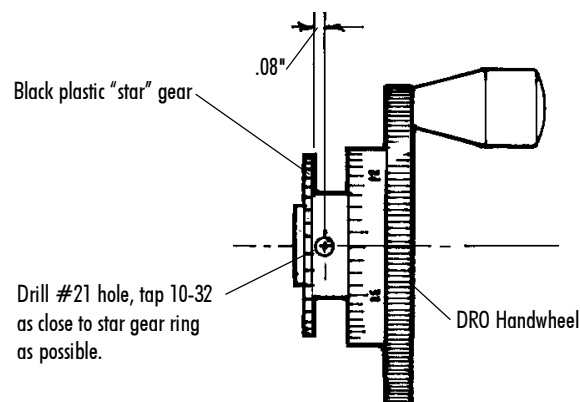

FIGURE 2—Location of new hole is as close to the star gear as possible.

Installing the handwheel and encoder housing

See the instructions that came with your P/N 8100 or 8200 DRO. The handwheel, encoder housing and sensor are now installed onto the thrust in the same manner as on a standard mill or lathe. See www.sherline.com/8100inst.htm if you do not have instructions at hand. If a reference line was not previously scribed in the center of the top of the housing cover, it should be scribed before assembling the two halves of the housing.

When installing the handwheel, align the set screw with the flat on the stepper motor shaft. Because of how close the set screw will be to the end of the shaft, it may be necessary to file or grind off the lip at the end of the flat so that the flat extends all the way to the end of the shaft.