

8

7

6

5

4

3

2

1

REVISIONS

EFFECTIVITY	SYM	DESCRIPTION	DATE	APPROVED
-------------	-----	-------------	------	----------

NOTES:

1. UNLESS OTHERWISE SPECIFIED:

A. BREAK EDGES .005.

B. SURFACE ROUGHNESS $\sqrt{63}$.

C. BLADES MILLED WITH 10 DEGREE E.M.
3/8" DIA @ 30 DEGREE SPACING X .820 DEPTH
REQUIRES 7 1/2 DEG ADDITIONAL ROTATION
TO ACHIEVE TAPER SHOWN

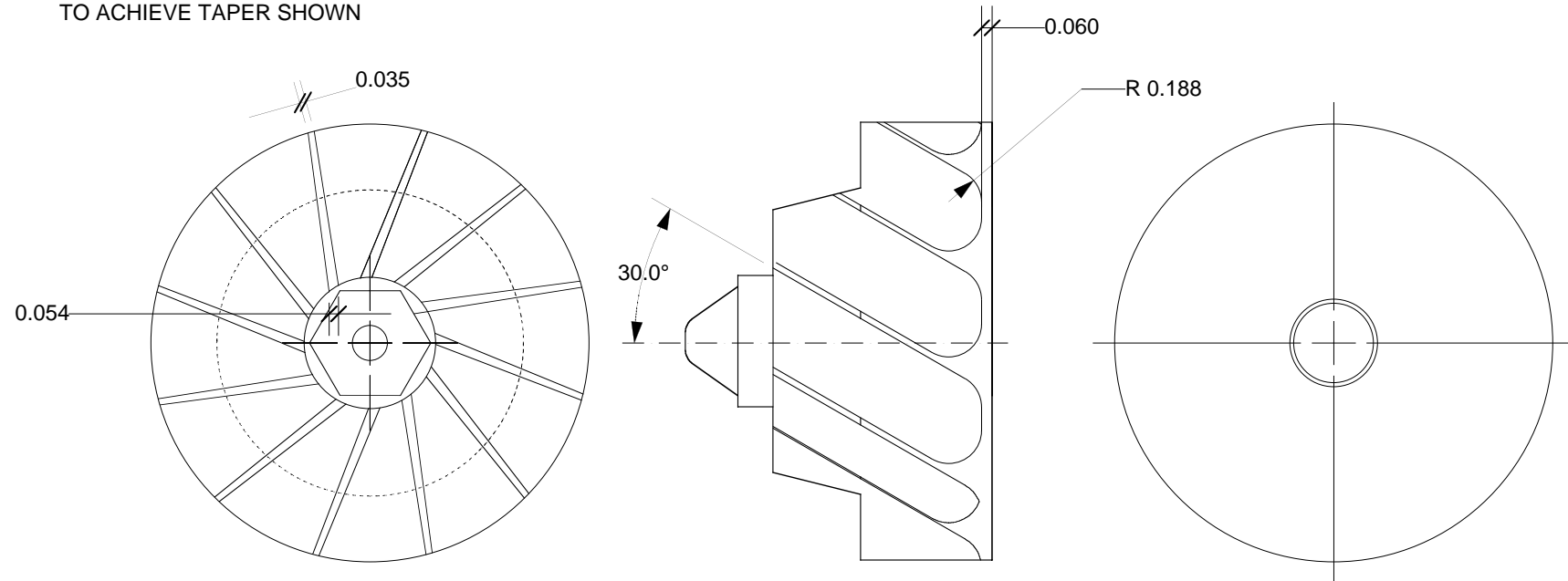

E

E

D

D

C

C

B

B

A

A

8

7

6

5

4

3

2

1

UNLESS OTHERWISE SPECIFIED DIMENSIONS ARE IN INCHES		
.XX +/- .010	.XXX +/- .005	ANGLES +/- 2 deg.
MATERIAL		
6061-T6511		
FINISH		
PART No.	NEXT ASSY	USED ON
APPLICATION		

QTY	PART NUMBER	DESCRIPTION	ITEM
LIST OF MATERIAL			
		Rosenfield Racing Team 1955 S. Palm St., Suite 6 Las Vegas, NV 89104 (702) 641-5815 (Ph) (702) 641-1883 (Fax) www.mini-trail.com	
PREP R. ROSENFELD 10 / 98		BLADE CONFIGURATION	
CHKR	APVD	SIZE A	NUMBER SC-101
APVD	SCALE 1 / 1		SHEET 2 OF 2